

Model PC420V Series Velocity Loop Powered Sensors (LPS™) with Dynamic Vibration Output



FEATURES:

- Peak equivalent, True RMS or True Peak output
- Corrosion resistant
- Hermetic seal
- ESD protection
- Overload protection
- Reverse wiring protection
- Dynamic signal output

The 4-20 mA output of the PC420V Series is proportional to velocity vibration. An output of 4 mA indicates a level of 0 ips or no vibration present. A full-scale reading of 20 mA indicates that the maximum range (Peak or RMS) of vibration is present.

The dynamic output signal is derived from an internal buffered amplifier. The dynamic output requires the 4-20 mA loop be powered. No constant-current supply diode is necessary, the BOV at the dynamic output is developed by the internal amplifier.

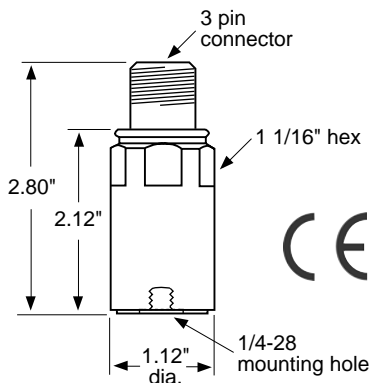

OUTPUT, 4-20 mA

Full Scale, 20 mA (±5%)	see Table 1 on back
Frequency Response:	
±10%	10 Hz - 1.0 kHz
±3 dB	2 Hz - 2 kHz
Repeatability	±2%
Transverse Sensitivity, max.	5%

OUTPUT, Dynamic

	PC420Vx-yy-DA	PC420Vx-yy-DV
Sensitivity (±10%)	100 mV/g	100 mV ips
Full Scale	20g	1.5 ips 1kHz
Frequency Response:		
±3 dB	2.5 Hz - 10 kHz	2.5 Hz - 2.5 kHz
Amplitude Nonlinearity, maximum	1%	
Resonant Frequency, mounted, nominal	25 kHz	
Transverse Sensitivity, max.	5%	

ELECTRICAL

Power Requirements (Two wire loop power):

Voltage at PC420-series sensor terminals	10 VDC min, 30 VDC max
Loop Resistance ¹ at 24 VDC, maximum	700Ω
Turn on time, 4-20 mA loop	< 30 seconds
Dynamic Output, Bias Output Voltage	+3.3 VDC, re: connector pin B
Dynamic Output Noise, equivalent g, 2.5 Hz - 10 kHz:	

	PC420Vx-yy-DA	PC420Vx-yy-DV
	2 mg	.002 ips
Grounding		Case isolated, internally shielded

ENVIRONMENTAL

Temperature Range	-40 to 85°C
Vibration Limit	250 g peak
Shock Limit	2,500 g peak
Sealing	Hermetic

PHYSICAL

Sensing Element Design	PZT ceramic / shear
Weight	162 grams
Case Material	316L stainless steel
Mounting	1/4 - 28 tapped hole
Output Connector	3 pin, MIL-C-5015 style
Mating Connector	R6G type
Recommended Cabling	J9T3A

ACCESSORIES SUPPLIED:

- SF6 mounting stud (International customers specify mounting requirements);
- Calibration data (level 2).

Table 1: PC420Vx-yy-Dz Dual Output Model Number Selection

x (4-20 mA Output Type)	yy (4-20 mA Full Scale)	z (Dynamic Scale)
R = RMS output, Velocity	05 = 0.5 ips	A = Acceleration 100mV/g
P = Equivalent Peak output, Velocity	10 = 1.0 ips	V = Velocity 100mV/ips
TP = True Peak output, Velocity	20 = 2.0 ips	
	30 = 3.0 ips	
	50 = 5.0 ips	

NOTES: ¹ Maximum loop resistance (R_L) can be calculated by:

$$R_L \text{ (max resistance)} = \frac{V_{\text{DC power}} - 10 \text{ V}}{20 \text{ mA}}$$

DC Supply Voltage	R _L (max resistance) ²	R _L (minimum wattage capability) ³
12 VDC	100Ω	1/8 Watt
20 VDC	500Ω	1/4 Watt
24 VDC	700Ω	1/2 Watt
26 VDC	800Ω	1/2 Watt
30 VDC	1.0kΩ	1/2 Watt

CONNECTOR PIN	FUNCTION
SHELL	ground
A	Loop Positive (+)
B	Loop Negative (-), Dynamic Common
C	Dynamic Output

² Lower resistance is allowed, greater than 10Ω recommended.

³ Minimum R_L wattage determined by: (0.0004 x R_L).

