

Model PC427xxx-yy-Dz-series Side Exit, 4-20 mA, Integral Cable Vibration and Temperature Voltage (LPS®)

FEATURES:

- Peak equivalent, True RMS, or True Peak
- Temperature signal output
- Optional dynamic signal output
- Corrosion resistant
- Hermetic seal
- ESD protection
- Overload protection
- Reverse wiring protection

BENEFITS:

- Choice of output: RMS, Equivalent Peak or True Peak; permits you to choose the sensor that best fits your industrial requirements.
- Provides continuous trending of overall machine vibration
- Can help guide maintenance

The 4-20 mA output of the PC427 Series is proportional to vibration. An output of 4 mA indicates a level of 0 ips or no vibration present for velocity output models and 0 g for acceleration output models. A full-scale reading of 20 mA indicates that the maximum range (RMS, Equivalent Peak or True Peak) of vibration is present.

The Dynamic signal output is an optional addition. Any of the base sensor models can also have dynamic signal output. Adding -DA to a model specifies a dynamic acceleration signal output (100 mV/g). Adding -DV to a model specifies a dynamic velocity signal output (100 mV/ips).

The temperature output of the PC427 Series is in terms of degrees Kelvin (°K), where zero °K = -273°C. The voltage output at 0°C = 2.73 Volts (273°K). The voltage output at 80°C = 3.53 Volts (353°K).

OUTPUT, 4-20 mA

Full Scale, 20 mA (± 5%) see Table 1

Frequency Response:

± 10% 10 Hz - 1.0 kHz
± 3 dB 4 Hz - 2 kHz

Repeatability ± 2%

Transverse Sensitivity, max. 5%

Output, temperature

Temperature Output Sensitivity, ±5°K 10 mV/°K

Temperature Measurement Range..... 223 to 358°K (-50 to 85°C)

OUTPUT, Dynamic (Optional)

PC427xxx-yy-DA PC427xxx-yy-DV

Sensitivity (± 10%) 100 mV/g 100 mV/ips

Full Scale 20g, peak 1.5 ips @1kHz

Frequency Response:

± 3 dB 2.5 Hz - 1.8 kHz 2.5 Hz - 1.8 kHz

Amplitude Nonlinearity, maximum 1%

Resonant Frequency, mounted, nominal 21 kHz

Transverse Sensitivity, max. 5%

ELECTRICAL

Power Requirements (Two wire loop power):

Voltage (between Black & Red wire) 10 VDC min, 30 VDC max

Loop Resistance¹ at 24 VDC, maximum 700Ω

Turn on time, 4-20 mA loop 30 seconds

Grounding Case isolated, internally shielded

Power Requirements (Temperature sensor):⁴

Current 0.4 to 5 mA

ENVIRONMENTAL

Temperature Range..... -40 to 85°C

Vibration Limit 250 g peak

Shock Limit 2,500 g peak

Sealing Hermetic

PHYSICAL

Sensing Element Design PZT ceramic / shear

Weight 320 grams

Case Material 316L stainless steel

Mounting 1/4 - 28 captive bolt

Cabling J95

CABLE WIRE	FUNCTION
SHIELD	Ground
Red	Loop Positive (+)
Black	Loop Negative (-)
White	Dynamic Signal (optional)
Yellow	Temperature Signal
Green	Temperature Common

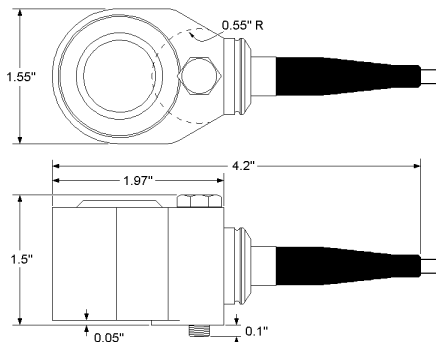

NOTES: ¹ Maximum loop resistance (R_L) can be calculated by:

$$R_L \text{ (max. resistance)} = \frac{V_{DC \text{ POWER}} - 10 \text{ V}}{20 \text{ mA}}$$

DC Supply Voltage	R _L (max resistance) ²	R _L (minimum wattage capability) ³
12 VDC	100Ω	1/8 Watt
20 VDC	500Ω	1/4 Watt
24 VDC	700Ω	1/2 Watt
26 VDC	800Ω	1/2 Watt
30 VDC	1.0kΩ	1/2 Watt

² Lower resistance is allowed, greater than 10Ω recommended

³ Minimum R_L wattage determined by: (0.0004 x R_L)

⁴ The temperature sensor must have a current flow to operate. This current can be provided through constant-current diodes (i.e. Vishay J508, etc.)

Table 1: PC427xxx-yy-Dz Model Number Selection

xxx (4-20 mA Output Type)	-yy (Full Scale)	-Dz (Dynamic Output) ^A	
AR = Acceleration, RMS AP = Acceleration, Equivalent Peak ^B ATP = Acceleration, True Peak ^C	-05 = 5 g (49 m/sec ²) -10 = 10 g (98 m/sec ²) -20 = 20 g (196 m/sec ²)	-DA = Dynamic Acceleration	100 mV/g (10.2 mV/ m/sec ²)
VR = Velocity, RMS VP = Velocity, Equivalent Peak ^B VTP = Velocity, True Peak ^C	-05 = 0.5 i.p.s. (12.8 mm/sec) -10 = 1.0 i.p.s. (25.4 mm/sec) -20 = 2.0 i.p.s. (50.8 mm/sec) -30 = 3.0 i.p.s. (76.2 mm/sec) -50 = 5.0 i.p.s. (127 mm/sec)	-DA = Dynamic Acceleration	100 mV/g (10.2 mV/ m/sec ²)
		-DV = Dynamic Velocity	100 mV/ips (3.94 mV/ mm/sec)

^A **Dynamic output is an option on all models.** If dynamic output option is not desired, do not add -DA or -DV to the model number.

^B **Equivalent peak** output is developed based on the true RMS value of vibration. For a pure sine wave, the equivalent peak output is 1.414 times the RMS value.

^C **True peak** output is based on the actual measured peak value using the time waveform and is not based on the RMS calculation.

PC427xxx-yy WIRING

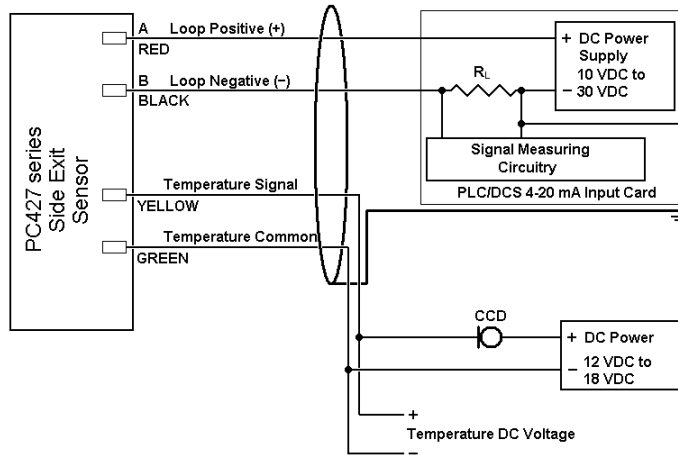

PC427xxx-yy-Dz WIRING

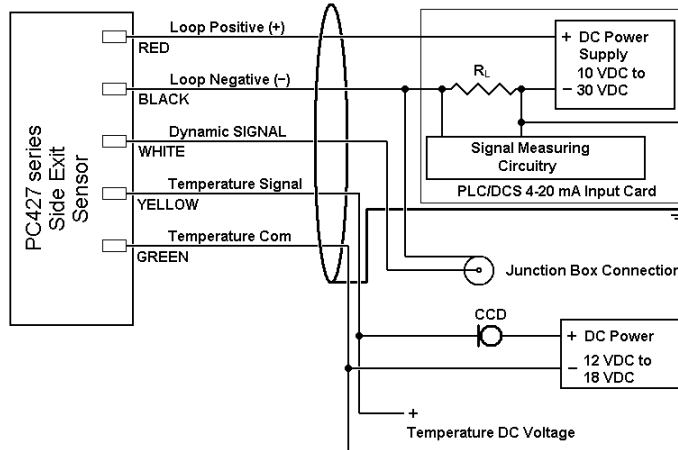

All wire and cable used for installation of the PC425-series sensor should be shielded. Generally accepted instrumentation wiring practice considers the best way to ground the shield is to connect it at only one end of the cable. The shield should not be wired to ground at both ends of the cable. The Wilcoxon pc427-series sensor has the shield connected to the case at the sensor end of the cable.

21 Firstfield Road, Gaithersburg, MD 20878 USA
1-800-WILCOXON
Tel 301-330-8811 Fax 301-330-8873
Email sensors@wilcoxon.com
Web www.wilcoxon.com



Due to continued research and development, Wilcoxon Research reserves the right to amend this specification without notice.